

3/4" CCMT (32.51) boring bar
Craig Durland
craigd@zenkinetic.com

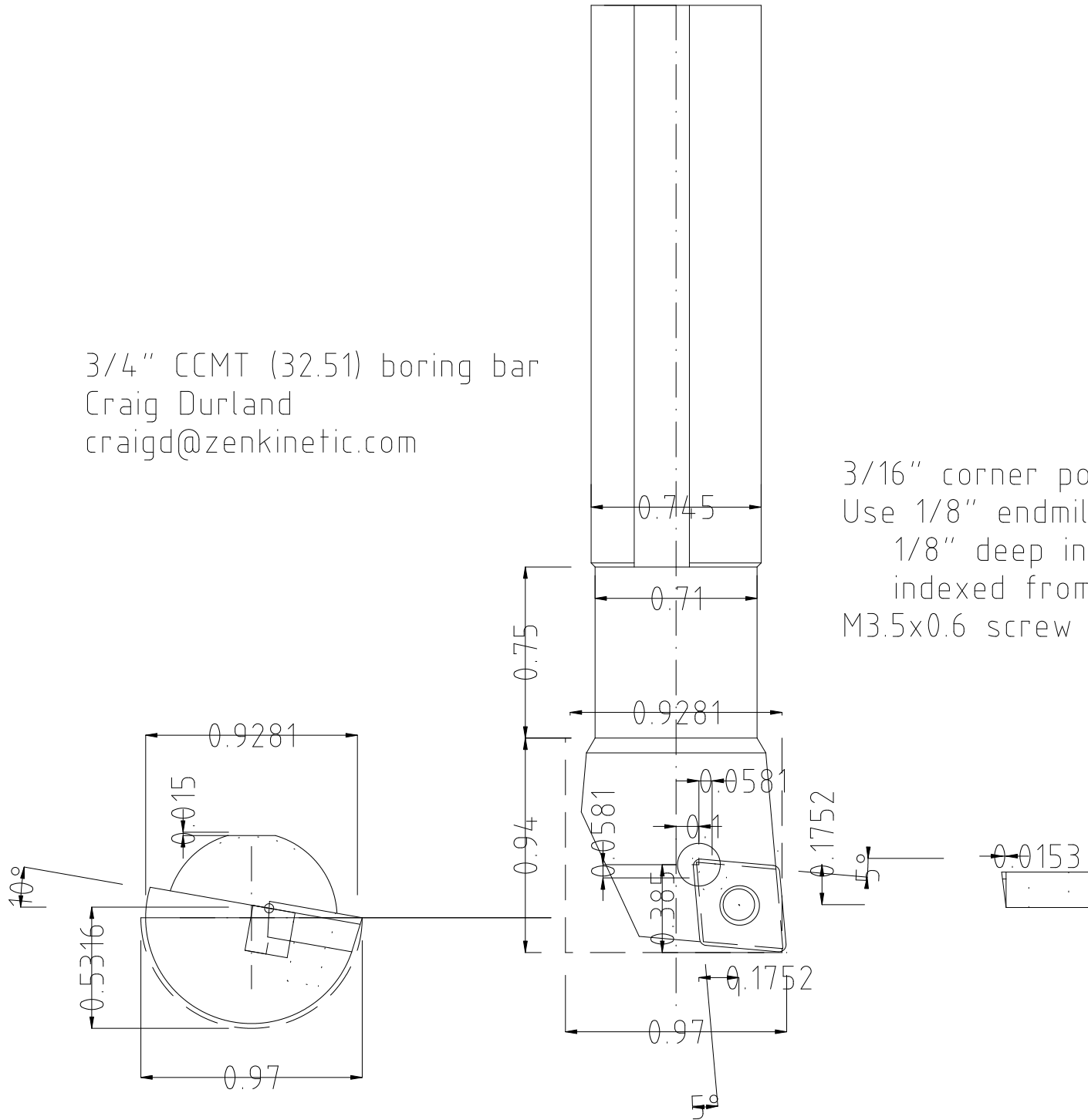

3/16" corner pocket 0.2" deep
Use 1/8" endmill to cut
1/8" deep insert pocket
indexed from 3/16" hole
M3.5x0.6 screw